



BRITISH

Isetta

OWNER'S HANDBOOK

*Presented by the
Isetta Owners Club
of Great Britain
to commemorate its
Tenth Anniversary*

1978-1988

CONTENTS

	<i>Page</i>
Alphabetical index - - - - -	4-5
Introduction - - - - -	6
Technical data - - - - -	7-9
Instrumentation and Control layout - -	10-11
Registration for police and customs authorities, data for filling stations and workshops - -	12
Controls and running-in instructions - -	12-16
Care of coachwork - - - - -	16-17
Technical maintenance - - - - -	18-28
Minor inspections and adjustments - - -	29-35
Maintenance survey - - - - -	35-36
Maintenance chart - - - - -	Pull out

ALPHABETICAL INDEX

	<i>Page</i>	<i>Figure</i>		<i>Page</i>	<i>Figure</i>
Adjuster plate, chain	33	70	Feeler gauge	30	58
Adjuster bolt, brake	34	76	Fill-up data	9	—
Air cleaner	24	42/43	Float chamber	32	69
Axle construction	8	—	Folding hood front rail	15	16
Battery maintenance	22/23	38/39	Front wheel bearings	24	44
Blower wheel	30/31	—	Fuel consumption	8, 15/16	—
Bore	7	—	Fuel line control tap	13	6
Brakes	8, 33/34	74/76	Fuel tank	9, 12	4
Brake adjustment	34	75/76	Fuses	25/26	47
Brake drum	33/34	—	Gear changing	13	8
Brake fluid	34	74	Gear lever	13	8
Brake master cylinder	34	74	Greasing	19	33/37
Brake pedal	34	—	Headlamps	26	48/49
Brake shoes	34	75/76	Height, overall	8	—
Canvas hood	15	16	Horn	27	—
Canvas hood maintenance	17	27	Ignition	30/31	62/65
Capacity	7	—	Ignition capacitor	27	—
Carburettor	31/32	66/69	Ignition coil	27	50
Carburettor adjustment	31/32	66/68	Ignition key	13	7
Care of coachwork	16/17	23/26	Ignition switch	13	7
Care of glass	17	28	Ignition test lamp	31	65
Carrying capacity	8	—	Ignition timing	31	—
Chain	32/33	—	Ignition warning light	27	—
Chain case	33	70/72	Instrumentation and control layout	10/11	1
Chamois leathering	16	24	Intake valve	29	—
Chassis frame	8	—	Jack	15	20/21
Choke lever	13	7	Jets	31/32	—
Cleaning, light metal parts	17	26	Kerb weight	8	—
Climbing ability,	8	—	King pins	19	—
Clutch	7, 33	—	Lamps	25/28	45/52
Clutch adjustment	33	73	Length, overall	8	—
Clutch pedal clearance	33	73	Lighting switch	13	9
Compression ratio	7	—	Locating pins	30	61
Contact breaker gap	31	62/63	Lubrication	7/9, 18/24	30/37
Contact gauge	31	62	Lucas electrics	21/23, 25/28	—
Contact plate	31	64/65	Main dimensions	8	—
Contact point lock screw	31	64	Maximum speed	8	—
Control layout	—	1	Number plate lamp	27	51
Cylinder head	—	—	Oil capacity	9	—
Dipper	13, 25	10	Oil change	18	30/32
Directional signal switch	13, 25	11	Oil dipstick	12	5
Door Hinge pins	19	37	Oil drain plug	18	30
Eccentric adjusting screw	31	63	Oil level, chain drive	18	32
Electrical equipment	7, 21/28	—			
Electrode gap	29	57			
Engine position	7	—			
Engine power	7	—			
Exhaust valve	29/30	—			

	<i>Page</i>	<i>Figure</i>		<i>Page</i>	<i>Figure</i>
Pedal shaft	19	36R	Tool kit	16	22
Polishing	17	25/26	Torque arm	19	35
Rear wheels	8	—	Track (tread) front	8	—
Reflectors	27	—	Track (tread) rear	8	—
Road performance	8/9	—	Transmission	7	—
Rocker arm	30	59	Transmission oil change	18	31
Rocker-box cover-gasket	30	60	Tyres	8	—
Running-in	14	—	Tyre pressure	23	40
Running-in speeds	14	—	Tyre wear	23	41
Seat adjustment	13	13	Universal joint, steering	19	36L
Seat removal	17	29	Valves	29/31	58/61
Sparking plugs	29	54/56	Valve adjustment	29/31	58/61
Speed limits	9, 14	—	Valve adjusting screw	29/31	59
Starter	7	—	Valve checking	29/30	59
Starter choke lever	13	7	Valve clearance	29	58/59
Starter switch	13	7	Valve stem	30	59
Starting	13	7	Ventilation	14/15	14/15
Steering	8	—	Volume control screw	32	67
Steering lubrication	19	—	Washing	16/17	23/28
Stop-tail lamps	28	52	Weight	8	—
Stroke	7	—	Wheelbase	8	—
Suspension	8	—	Wheel changing	15	17/21
Swing arm	19	—	Wheel cover plate	15	18
Tail lamp	28	52	Wheel spare	15	17
Technical data	7/9	—	Width, overall	8	—
Technical maintenance	18/23	30/44	Windscreen wiper	13, 28	12, 53
Terminal block	27	—	Wire brush	29	56
Three-way fuel tap	13	6	Wiring diagram	28	Pull out

INTRODUCTION

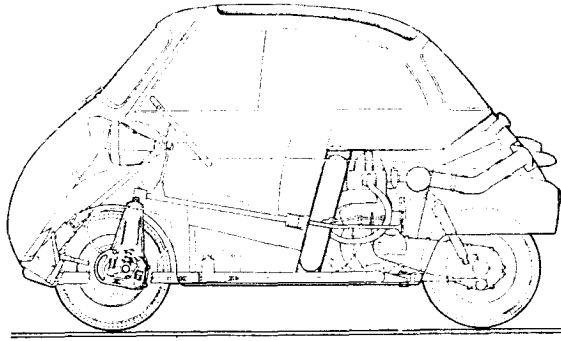

In the following pages you will find described in non-technical language everything the Isetta driver needs to know about his vehicle.

Where technical details do occur, such as on the succeeding two pages, they are included mainly for service stations and for the more technically-minded Isetta owner.

The British-manufactured Isetta is a new solution to motoring problems. Its manoeuvrability in dense traffic; the absolute weather-protection which at the same time permits draught-free open-air driving by means of the folding sun roof; its comfortable interior dimensions; its quick acceleration and considerable top speed given by a high performance air-cooled engine unit; and above all its tremendous mileage; these are advantages that will certainly suit new trends in motoring.

You will find the Isetta an easy-to-handle runabout, suitable for city and country driving, for field-track and modern highway alike. Furthermore, excellent road holding and a brake system of remarkable efficiency ensure a maximum of driving safety.

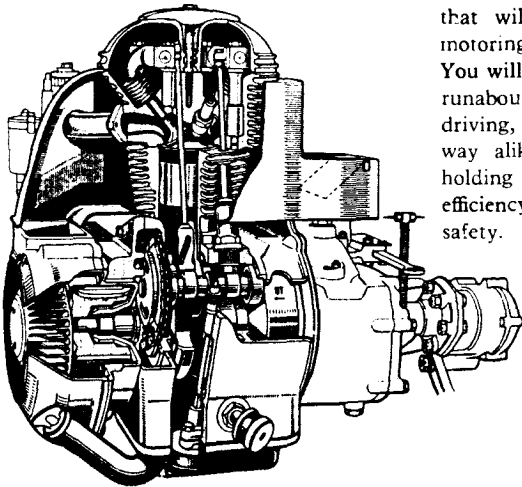

6

SERVICING

Isetta Service Stations are organised in the form of a wide net of Isetta Agencies. They are always at your service. At these Service Stations you will find technicians who have been specially

trained at the Isetta factory or by factory representatives. Each of these Service Stations is equipped with proper tools and has a complete stock of genuine spare parts.

Technical data :

Engine :	BMW single-cylinder, four stroke engine, blower cooled
	300 c.c. engine
Bore	72 mm (2.83 in.)
Stroke	73 mm (2.87 in.)
Capacity	295 c.c. (18.30 cu. in.)
Compression	6.8 to 1
Power	13 bhp at 5,200 rpm
Valves	Overhead, in V-arrangement
	Valve timing measured at .08 in. in valve clearance :
	Intake opens 6° before T.D.C.
	Intake closes 34° after B.D.C.
	Exhaust opens 34° before B.D.C.
	Exhaust closes 6° after T.D.C.
Lubricating system	Force feed lubrication
Clutch	Single plate dry clutch
Engine position	Right hand side, transverse behind the seat
Starter	12 volt dynamo starter Noris, LA 12/130 R.
Electrical equipment	12 volt/130 watt generator with voltage regulator Lucas 12 volt/32 amps battery and lighting equipment
Sparking plug	Lodge CC14
Carburettor	Bing starter carburettor 1/22
Transmission :	Gearbox four forward speeds and reverse
	Gear ratios :
	1st 10.05 23.21
	2nd 5.17 12.14
	3rd 3.54 8.17
	4th 2.70 6.1
	Reverse 12.15 30.0
	Overall gear ratios :

7

Transmission continued

Final drive Final drive 2.31 (13/30 teeth) through transverse resilient mounted drive shaft and totally enclosed fully adjustable chain drive in oil bath.

Chassis frame : Rigid tubular chassis frame constructed by Rubery Owen & Co. Limited.

Axle layout and suspension :

Front wheels Independent front wheel suspension, swinging arms, coil springs and shock absorbers.
Camber 1½ deg.
King pin inclination 5°, in castor 12°, toe-in 4 to 5 mm = 5/32 in. to 3/16 in., measured on the rim borders, front and rear.

Rear Wheels Suspension by quarter elliptic leaf springs and telescopic shock absorbers.

Wheels : Steel disc wheels by Dunlop. Rim size 3.50 in. × 10 in.

Tyres: Four Wheels Tubeless tyres, size 4.80 in. × 10 in.
and Three Wheels

Steering gear : Worm and nut, turning circle approx. 24 feet.

Brakes : Hydraulic braking to all four wheels. Brake diameter 7 in.
Total brake lining area 50.25 sq. in.

Dimensions :

Track (tread), front	47.2 in.
Track (tread), rear (four wheeled Isetta)	20.4 in.
Wheelbase	58 in.
Overall length	89.9 in.
Overall width	54.3 in.
Overall height (unladen)	52.6 in.

Weight: Four Wheels Kerb weight approx. 770 lbs.
Three Wheels Kerb weight approx. 750 lbs.
Carrying capacity 507 lbs.
(N.B. Carrying Capacity refers to both)

Maximum speed : 52 mph

Climbing ability : First gear 1 in 3

Average fuel consumption : 76 miles/Imp. gal.

Oil consumption : Approx. 3.5 Imp. pints per 1,000 miles

Fill-up data :

Fuel tank 2.8 Imp. gal. = 3.4 U.S. gal. with reserve fuel supply of .65 Imp. gal. (.8 U.S. gal.)

Oil capacity, engine 3.1 Imp. pints = 3.6 U.S. pints

Oil capacity, gearbox 1 Imp. pint = 1.2 U.S. pints

Oil capacity, chain drive .44 Imp. pints = .55 U.S. pints

Tyre Pressure: Four Wheels 16 lbs. **Front and Rear**

Three Wheels Front: 16 lbs. Rear: 28 lbs.

Fuels and lubricants:

Fuel Regular or Premium grade

Lubricant See lubrication chart

Recommended Speeds: (mph)

	1st	2nd	3rd	4th
During running in	9	18	28	37
(Permissible cruising speeds				
after running in period)	12	25	37	50
Maximum speeds	15	28	40	52

Fuel Consumption Curves

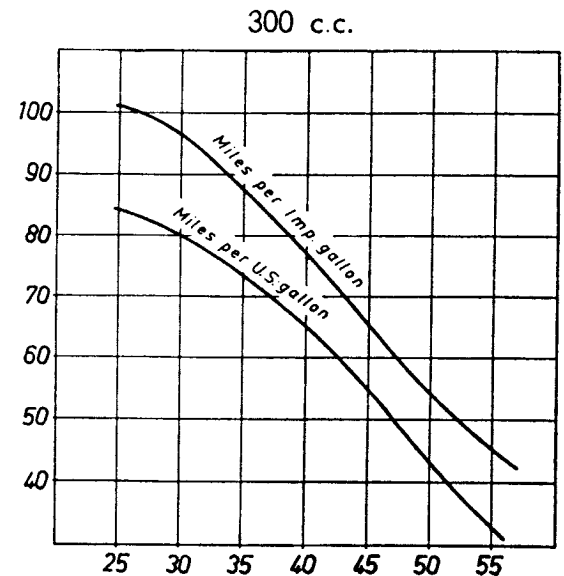

INSTRUMENTATION & CONTROL LAYOUT

Left hand Drive

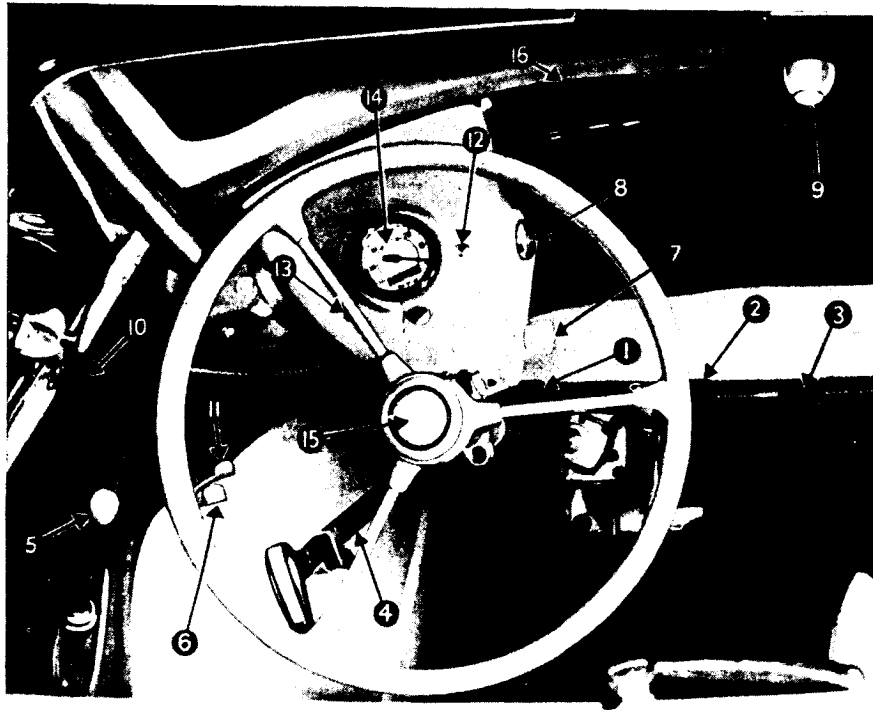

- | | |
|---------------------------------|--------------------------------------|
| 1. Clutch pedal. | 9. Directional signal switch. |
| 2. Brake pedal. | 10. Headlamp dipper switch. |
| 3. Accelerator pedal. | 11. Heater. |
| 4. Hand brake. | 12. Ignition control light. |
| 5. Gear lever. | 13. Headlamp main beam warning light |
| 6. Choke lever. | 14. Speedometer. |
| 7. Lighting switch. | 15. Horn button. |
| 8. Ignition and starter switch. | 16. Windscreen wiper motor. |

Right hand Drive

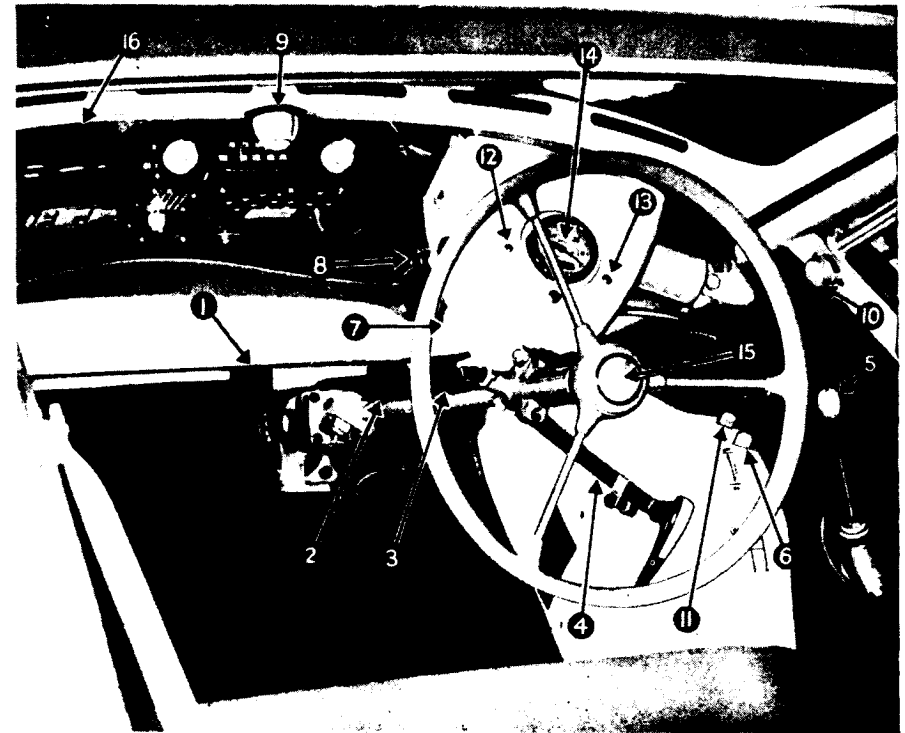

- | | |
|---------------------------------|---------------------------------------|
| 1. Clutch pedal. | 9. Directional signal switch. |
| 2. Brake pedal. | 10. Headlamp dipper switch. |
| 3. Accelerator pedal. | 11. Heater. |
| 4. Hand brake. | 12. Ignition control light. |
| 5. Gear lever. | 13. Headlamp main beam warning light. |
| 6. Choke lever. | 14. Speedometer. |
| 7. Lighting switch. | 15. Horn button. |
| 8. Ignition and starter switch. | 16. Windscreen wiper motor. |

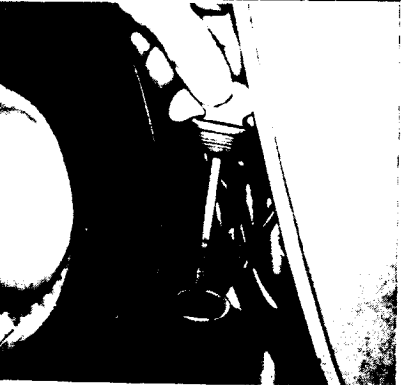
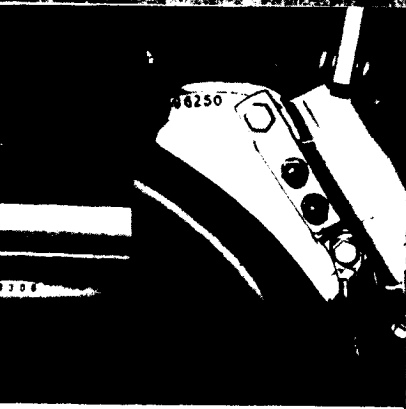
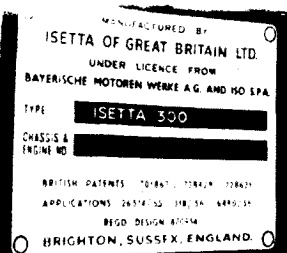

2

For police and customs authorities

Serial plate :

Inside at the right in front of the seat (figure 2)

Chassis number :

On front cross member of frame, below the right-hand door corner (figure 3, left, number 1)

Engine number :

On engine housing to the right of blower case (figure 3, right, number 2)

3

For filling stations and workshops

Fuel tank :

In the rear end of vehicle, access from outside

Capacity 2.8 Imp. gal. = 3.4 U.S. gal. with reserve fuel supply of .65 Imp. gal. = .8 U.S. gal. (figure 4)

Engine oil filler :

Oil filler and dipstick on right-hand bottom side of engine. Maintain oil level up to the mark on dipstick (figure 5).

4

Oil capacity 3.1 Imp. pints=3.6 U.S. pints. Branded oil SAE 40 for summer use and SAE 20 for winter. Multigrade 10W/30 for overseas.

The new Isetta owner will probably have had experience as a driver or, at any rate, will have had tuition from a driving school. It is, therefore, unnecessary to include within the scope of this manual details about how to use clutch, accelerator and other controls. With the British-

5

manufactured Isetta these controls are accommodated in a convenient arrangement that makes for easy handling.

The lever for the three-way fuel line control tap, situated behind the seat squab, is easily reached with your right or left hand (figure 6). When starting from cold, pull choke lever full back (figure 7); at the same time turn the ignition key with the other hand (thereby switching on the ignition) and push same in with a further short clockwise rotation to operate the starter motor. As soon as possible after the engine fires, reset the choke lever into its foremost position. The gear change mechanism works smoothly especially if you get into the habit of pulling the gear lever with the fingers and pushing it with the palm of your hand (figure 8) instead of grasping it with your whole hand. If first gear does not engage at once, release the clutch a little or clutch and declutch again for an instant.

The heating for the interior, which is an optional extra, is hand-controlled by moving the larger lever situated just beneath the choke lever. The lighting switch located below the steering wheel is also within reach (figure 9.) The switch for dipping and raising the headlamp beams is situated below the sliding windows and just above the gear lever (figure 10). The directional signal switch is mounted in the centre of the door below the windscreen (figure 11). To bring the windscreen wiper into operation, push the switch of the motor unit which is fitted to the door (figure 12). To adjust seating, slacken the two screws underneath the seat and adapt the seat position to your requirements (figure 13).

For the other controls and instruments see pages 10 and 11.

13

6

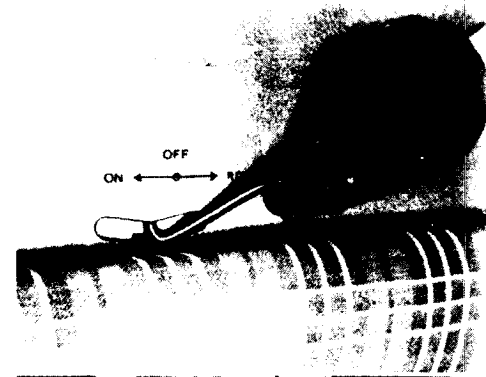

7

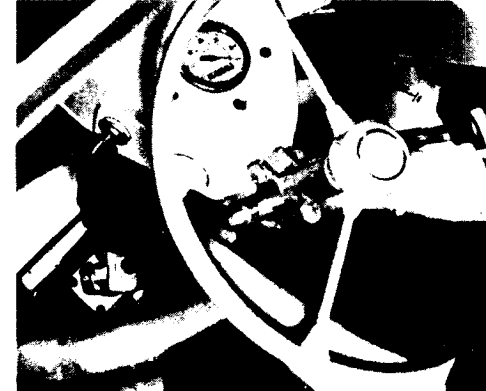

8

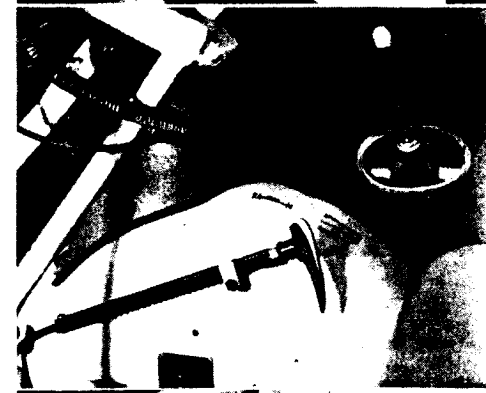

9



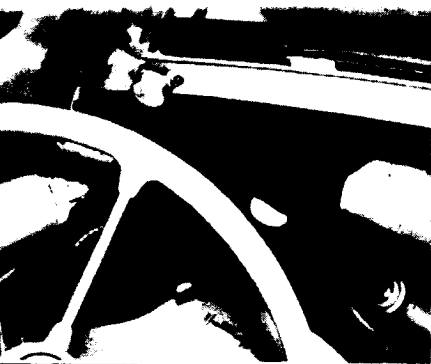

10 Your friends may have told you about running in a new vehicle. On the other hand you may well already have had experience of it yourself. In any case, it is not a complicated operation. Do not be afraid to give your Isetta plenty of work to do, even in the first weeks—continuous development has made its engine a marvel of precision and robustness. Correct use of the gear box will avoid engine overloading during the first 600 miles and, provided the recommended running in speeds are *strictly* observed the engine will respond with long service and good performance.

11 For the first weeks of the running-in period, that is for the first 600 miles, we recommend the following speed limits :—

- 1st gear : not over 10 mph
- 2nd gear : not over 18.5 mph
- 3rd gear : not over 28 mph
- 4th gear : not over 37 mph

These speed indications correspond with an engine rate of 4,000 to 4,500 rpm, whereas the speeds mentioned under 'Technical data' will be reached at a rate of about 5,200 rpm.

After the first 600 miles you may on occasions use your BMW engine's full power output. After 2,000 miles you may consider the engine as being completely run in. You may then use the cruising speeds indicated on page 9.

12 The red markings I, II, III on the speedometer dial show the cruising speeds for first, second and third gear. In fourth, the speed range available within the red-coloured section should only be used for the purpose of passing other vehicles.

The British-manufactured Isetta has many other advantageous features not so far mentioned. For instance, the two sliding windows have stop spring catches

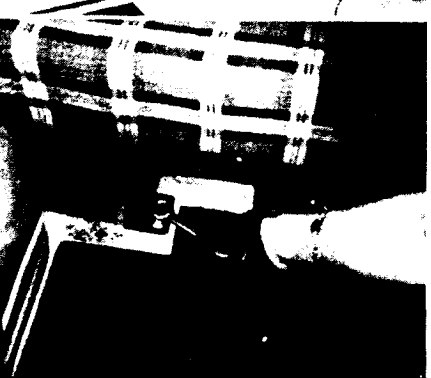
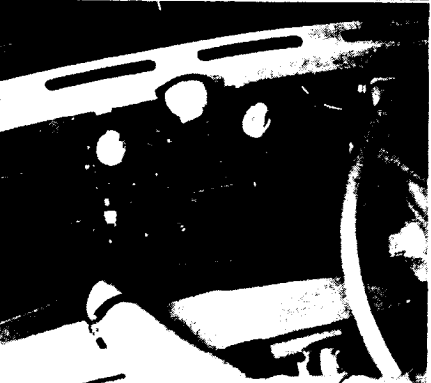
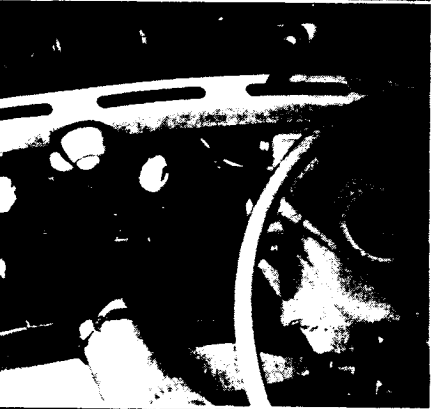

13

14

to prevent opening from outside while the vehicle is parked. To open a window, press the button of the locking device and simultaneously push the window to the desired position. All windows are made of toughened safety glass (figures 14/15).

The folding sun roof is opened by operating the lever situated on the middle of the front rail. After rain, do not open the roof until it is completely dry. To close the canvas hood, draw the front rail forward and lock with the lever (figure 16).

In the case of wheel changes, removal of the spare wheel (an optional extra) is achieved by pulling the rear of the seat forward and lifting the spare wheel from behind (figure 17). Wheel-changing, which should be carried out not only in the event of a damaged tyre, but in any case at regular intervals (see also page 23 and 24, figures 40 and 41) does not involve any trouble, though it should be done with care. The jack is stowed beneath the seat. Figures 18, 19, 20 and 21 show the method of wheel removal and jacking positions front and rear.

The way in which you drive considerably influences the fuel consumption. You will profit by the economy of the BMW engine provided that you use accelerator and brake-pedal in a careful manner. Every vigorous movement of your right foot, every full depression of the accelerator pedal or brake pedal, costs fuel. Therefore, try to adopt modern methods of changing gear. If, for instance, you drop from a higher speed to 25 mph in city traffic, and then want to accelerate, you should shift from 4th into 3rd and only change up again when you have regained the higher speed. If the traffic speed is 25 mph stay in third gear at

14



15

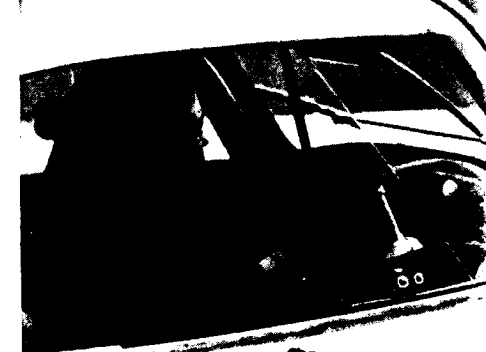

16



17



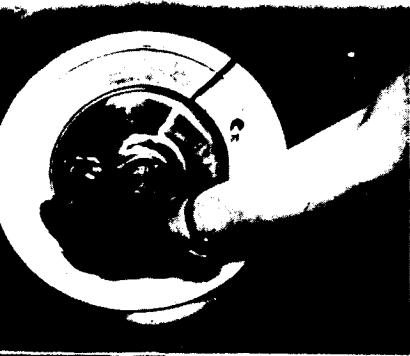

18

half-throttle opening. In this way you will spare your engine and you will save fuel. BMW engine is designed for high revolutions and it will not suffer if you raise the revolution rate in the lower gears in traffic so as to get away quickly. With the remarkable acceleration and manoeuvrability of the British Isetta you can easily wind through narrow spaces and always keep up with the flow of traffic.

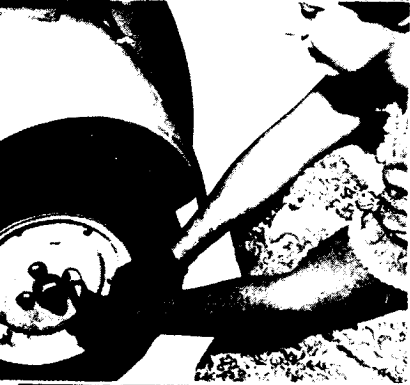

19

Care of coachwork

The tool-kit (figure 22) contains all the items you need for maintenance and minor repairs. Washing your Isetta requires some care; the following procedure should be adopted.

First flush the chassis and lower part of the body with water from a low pressure open-end hose, to soak off dirt. Afterwards a brush should be used. Washing of the varnished areas to remove injurious dirt-accumulations and dust should be done when the body is cold; never wash or polish your Isetta in the direct rays of the sun or while the body is still hot from having been exposed to sunshine. Apply an even spray of clear water on the exterior finish until the dirt is removed. Do not allow a strong jet of water to hit the varnished surface.

20

Using plenty of water, dirt should be removed with a clean sponge (figure 23). Clean the sponge at short intervals. Next use the wrung-out sponge to wipe off all drops of water and then rub the lacquer dry with a clean, soft chamois to avoid water spots (figure 24). If water alone does not do the job the varnished areas may be given a second wash with lukewarm water, soapy water (1 to 2 per cent) or shampoos. Do not, however, use

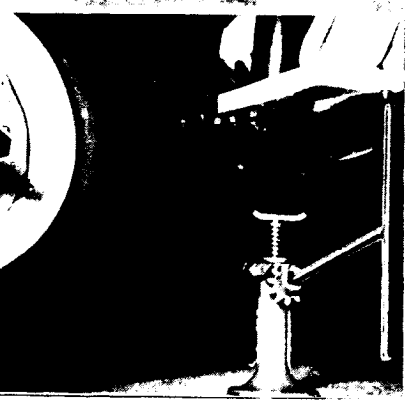
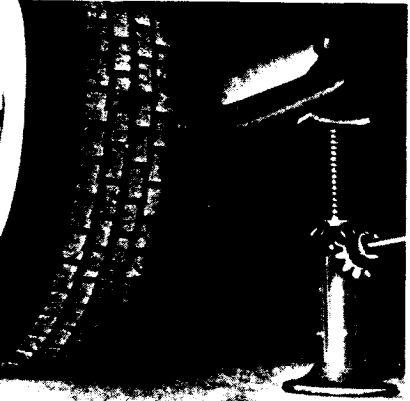

21

16

soap or shampoo too strong or the varnish will become brittle. After soapy water or shampoo treatment wash the body thoroughly with clear water and polish with a good quality wax (figure 25). Wax polish should be applied with a soft polishing cloth or polishing cotton in small quantities upon the completely dry finish, doing only a small area at a time. Remove the wax, using a clean polishing cloth, until the original brilliance is restored. Light metal parts, such as bumpers, window frames, etc., which have become opaque or spotted, should be coated with a chromium-nickel polish and then rubbed with a clean, soft linen cloth or wad until the original brilliance is restored (figure 26).

Maintenance of the canvas hood is easily carried out. Dust should be removed with a soft brush. From time to time clean the canvas hood with a washing-brush, using plenty of water (figure 27). Never try to remove spots with gasoline or other chemical products, but rather use a good textile cleaner as you would use it for removing spots from clothes.

Care should be taken in the maintenance of the window panels. In order to avoid scratches on the safety glass surface, the adherent dust should be removed with a duster, or, better, with plenty of flowing water by means of a hose and sponge (figure 28). It should never be rubbed off with a linen cloth. Should you wish to remove the seat of your vehicle in order to carry out interior maintenance, first remove the spare wheel in the manner already described and then fold the seat and turn it into the gap which contained the spare wheel. Finally draw the seat on its left corner forward and raise and remove in an upward direction (figure 28).

17

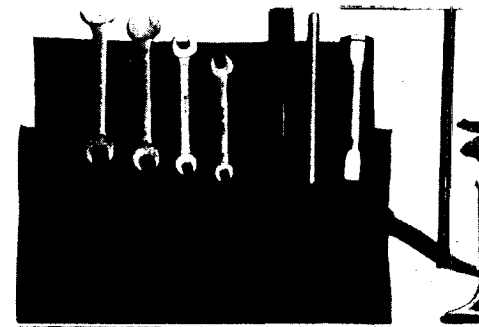

22



23



24



25



26 Technical maintenance

The following items can well be dealt with by the owner:—

(a) Changes of oil in the engine should be carried out after the first 300 miles, thereafter every 1,000 miles. To achieve this unscrew the drain plug at the bottom of the crankcase (figure 30). After the last traces of old oil have drained, replace and tighten the drain plug before filling with the new oil up to the height of the level mark on the dipstick. The oil capacity is 3.1 Imp. pints = 3.6 U.S. pints.

27 Draining should take place with the oil still warm. On no account use flushing oil to flush the engine.

(b) Similarly the oil while still warm should be drained from transmission and chain drive. The transmission drain plug is reached from the side opposite the engine, at the bottom of the gearbox case (figure 31, left). The transmission filler plug is located below the air filter in front of the mudguard of the right-hand rear wheel (figure 31, right). Having drained the transmission oil and thoroughly tightened the drain plug, fill up with transmission oil through the filler orifice until it can be seen in the filler hole. The topping up should be done in the same manner. Oil capacity approx. .96 Imp. pint = 1.1 U.S. pints.

28 The oil level of the chain case and rear axle assembly is checked through the filler orifice in the rear axle unit (figure 32). The oil should reach the lower threads of the plug hole. The drain plug is situated just beneath the filler orifice and is marked by an arrow in figure 32. The oil capacity

29

18

of this unit is about .5 Imp. pint = 6 U.S. pint.

The simplified design of the British Isetta features only eight grease points, four on the front suspension (figures 33, 34 and 35), two in the cabin on the steering and pedal controls (figure 36) one on the handbrake cable and one on steering arm shaft. Each of the front suspension units features two grease nipples and one oil filler plug. The grease nipples serve to lubricate top and bottom bearings of each steering knuckle king pin. The grease gun should be applied to them every 1,000 miles at Service A.

The oil filler plug gives access to a small oil reservoir that lubricates the fulcrum bearings of the swing arm and the newly introduced torque arm (figure 35).

Use engine oil SAE 40 for this lubrication point. Refill initially at 300 miles and subsequently every 2000 miles at Service B. Top up to about the middle of the filler hole thread.

The remaining two grease points are the universal joint at the lower end of the steering column, accessible by opening the door (figure 36 left), and the shaft for the foot pedals (figure 36 right). The old, emerged grease should be properly removed on these two latter points as they are located within the body and do not get splashed by dirt and moisture.

Joints lacking grease nipples, such as the door-hinge pins, the yoke pins on the linkage mechanism of the pedal shaft (see lubrication chart at the end of the booklet) and all other parts causing friction should be given a few drops of oil from time to time (see lubrication chart) by means of an oil can (figure 37). For greasing use a lubricating-grease (all makers' recommended lubricants) which should incidentally always be stored in its securely closed container in order to prevent the ingress of dust and dirt.

19

30

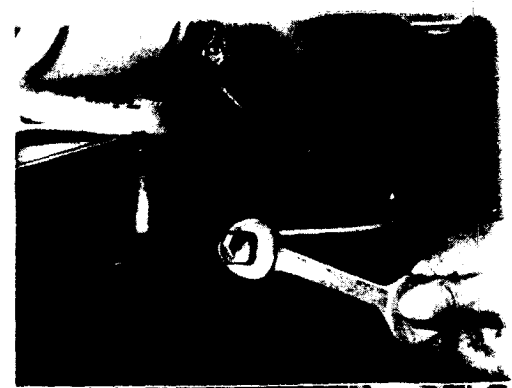

31



32



33

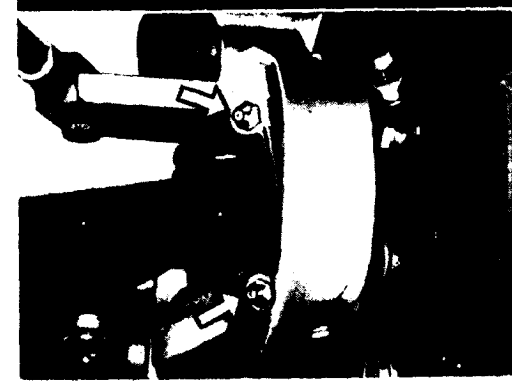



Wheel Change for Three-Wheel Isetta

Jack up rear wheel placing jack under the rear, i.e., left-hand side, rear spring eye adjacent to axle.

With box spanner or brace (Fig. 1), remove the four wheel nuts and backing plate. Now remove wheel to the right (offside) until clear of bolts, and then lower to ground (Fig. 2).

When replacing the wheel, it must be pushed through the aperture between wheel studs and swing arm (Fig. 2), and the side of wheel on which the inflating valve is fixed should be next to the brake drum. Note that the distance pieces must be replaced so that the tapered side is nearest the wheel.

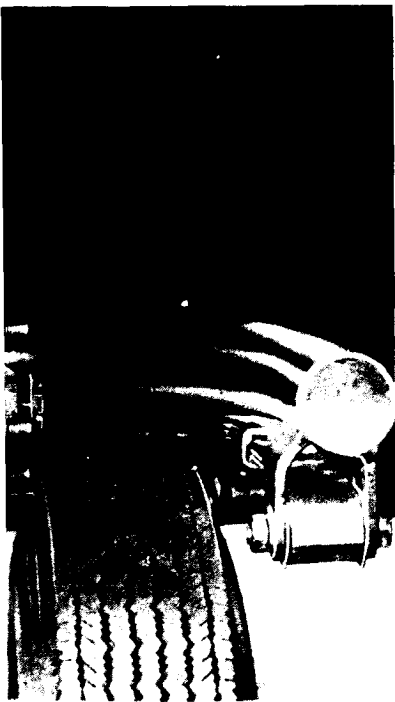

HEADLAMPS for Three-Wheel Isetta for Plus model only

Each headlamp contains a Lucas Light Unit secured by five W-shaped wire clips to the front rim. The Light Unit consists of an aluminised reflector permanently attached to the front glass which is lensed to form an optical system of flutes and prisms. The bulb has two filaments, main and dip, and these are connected through the dipper switch to provide double-dipping of the headlamps. The filaments are fed through a Lucas adaptor (554691). Lucas Bulb No. 355 12-volt 42/36 watt, B.P.F. cap.

HOW TO REPLACE BULB

Slacken the screw at the bottom of the front rim and withdraw the rim and Light Unit assembly. Access to the bulb is gained by releasing the bayonet-fixed adaptor with a press-in anti-clockwise motion. It should be noted that a notch in the flange of the bulb is arranged to locate with a ridge in the bulbholder to ensure that the bulb is non-reversible. The bulb is of a pefocus pattern.

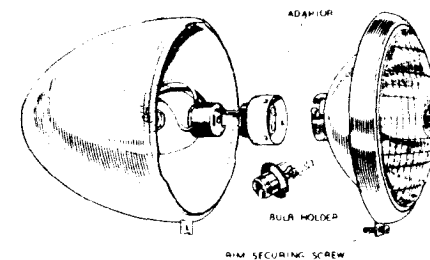

Headlamp Bulb Replacement.

HEADLAMP SETTING

The Headlamps should be set so that when the vehicle carries its normal load the main beams are projected straight ahead, parallel with each other and with the road. The setting should be rechecked after replacing a defective bulb. The lamp bodies are secured to the vehicle by four set screws access to which is gained by removing the interior trim panels. These screws must be slackened when it will be found that the lamp bodies can be adjusted to give the correct setting.

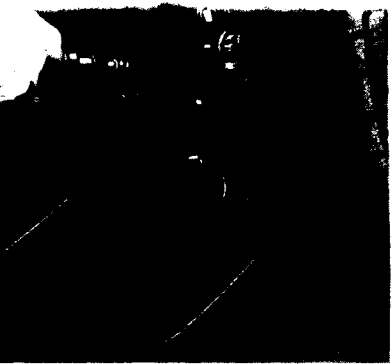

34 **Lucas electrics
Battery**

Model HO7A/8; Type, Lead-Acid; 12 volt; 7 plates per cell. Capacity, 32 ampere-hours at the 10-hour rate and 31 ampere-hours at the 20-hour rate; first charge current 2 amperes; recharge current 3 amperes.

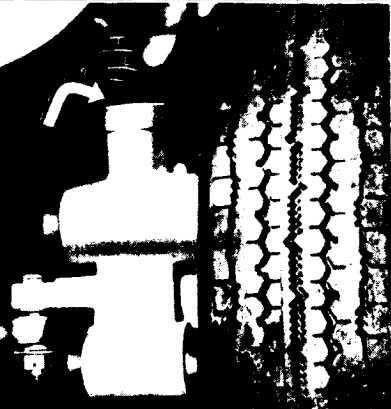

35 Access to battery for topping up (see figure 29 page 18). Every 1,000 miles or monthly, whichever is the lesser, remove the filler plugs from the battery and inspect the electrolyte level with the top edges of the inter-plate separators. This addition will replace water lost by evaporation.

The use of a Lucas Battery Filler enables the correct electrolyte level to be obtained automatically (figure 38).

Use only distilled water.

Never overfill the cells.

Never hold a naked light near the cell tops.

Keep the cell tops dry.

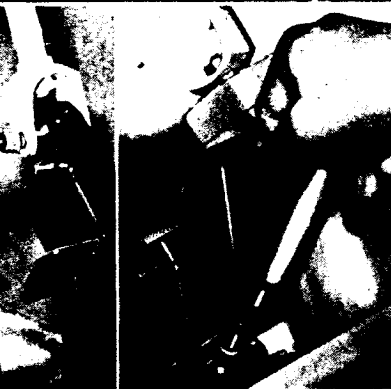

36 Run the vehicle immediately after topping up in cold weather. This will help to mix the distilled water and electrolyte and so prevent freezing and possible damage to the battery.

General care: Keep the cell tops clean. Keep the electrical connections and fixing bolts tight.

Hydrometer readings: Hydrometer readings indicate the condition and state of charge of the battery. Good cells will yield clear electrolyte free of particles in suspension and will produce high specific gravity readings. It is advisable to take



37

hydrometer readings from time to time, but, to avoid low misleading readings, such measurements should not be made immediately after topping-up (figure 39). The readings shown below are given for ambient temperatures normally below and above 90°F.

Climates below 90°F	Climates above 90°F
(i) 1.270-1.290	1.200-1.220
(ii) 1.190-1.210	1.120-1.140
(iii) 1.110-1.130	1.040-1.060

The indications given by these readings are as follows:—

- (i) Cell fully charged
- (ii) Cell about half discharged
- (iii) Cell completely discharged

The readings for all cells should be approximately the same. If widely varying readings are obtained the battery should be examined at a Lucas Service Depot or by an official Lucas Agent.

Storage: Never leave the battery in a discharged condition. If the vehicle is to be out of use for an appreciable period, the battery should first be fully charged and, subsequently, should receive a short refresher charge every fortnight.

Technical Maintenance (cont.)

Tyre pressures should be checked (figure 40) at frequent intervals and at least once a week. If you use your own tyre gauge, check it from time to time with a calibrated tyre gauge at a filling station. The tyre pressures should be adjusted to 16 lbs./sq. in. (front and rear) and 16 lbs. front and 28 lbs. rear on three wheelers. In order that tyre wear should be uniform with the spare wheel tyre, you should change the wheels round from time to time. The manner of rotating the wheels is shown by figure 41. Periodical maintenance should also include care of the air cleaner. This filter

38

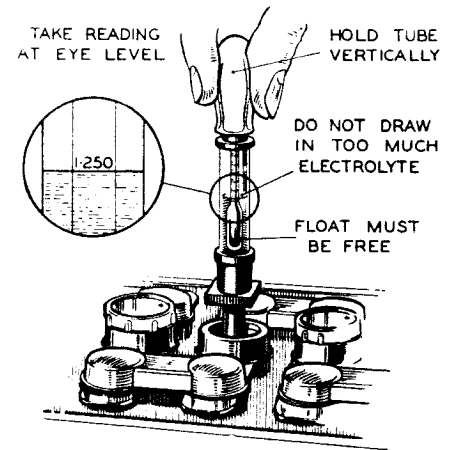
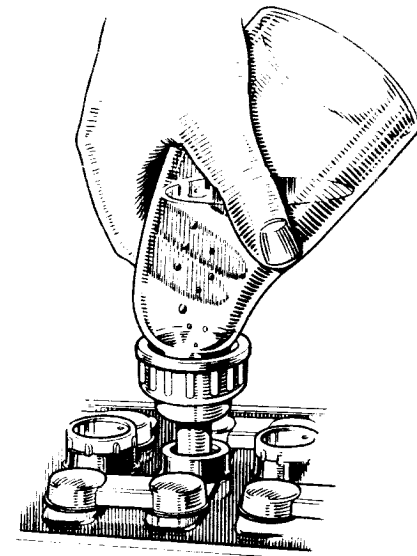

39

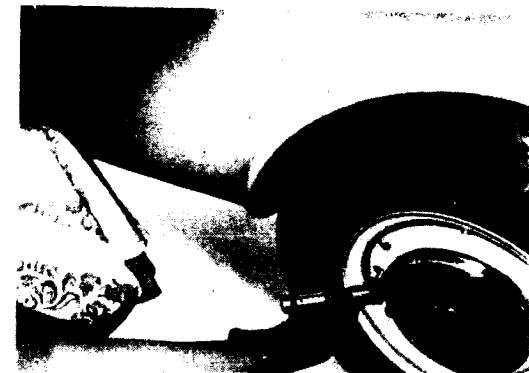

40

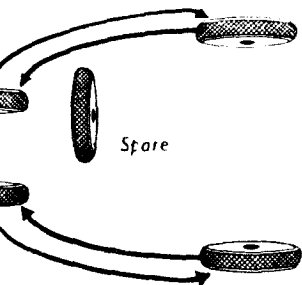

41

is of the dry element type and should be cleaned every 2,000 miles. To do this unscrew the rubber hose-clip on the carburettor with a screwdriver. Push the rubber tube away from the carburettor (figure 42 left). Next loosen the toggle-action clips on the filter. On gripping the air cleaner let the toggle-action clips snap back. Tap the filter gently on wooden block to expel dust (figure 42, right).

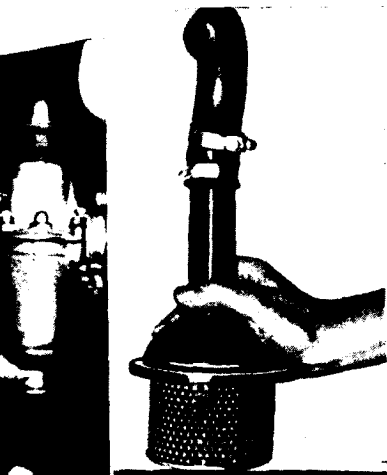

42

The filter element should be replaced every 7,500 miles (see Service C). To carry out this replacement slacken the fixing screw with a 9 mm spanner, remove the cleaning element and fit a new element (figure 43).

The transmission of movement from clutch pedal to clutch unit, from accelerator pedal to carburettor and from air lever to carburettor is achieved by Bowden cables. These cables should be checked from time to time if necessary and lubricated. These jobs, however, are best done by a service station. They should be performed at intervals of about once a year or every 7,500 miles as indicated in the maintenance chart, and therefore belong to the maintenance items of Service C (page 33 and appendix).

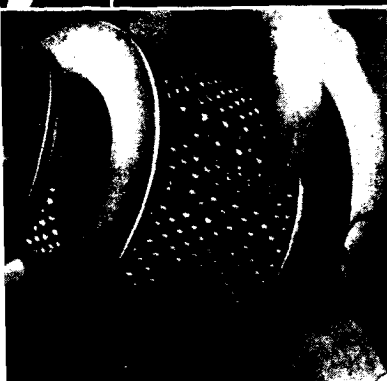

43

There is a final maintenance job which should be carried out every 7,500 miles (also see lubrication chart on last page). The grease loads in the ball-bearings diminish at a very slow rate, so that the grease in the front-wheel bearings needs to be renewed only occasionally. For this purpose remove the wheel-cover plates and with a clean finger press the fresh ball-bearing grease into the bearings. Under no circumstances fill the dust cap completely and replace because this may inject grease into the brake linings (figure 44).

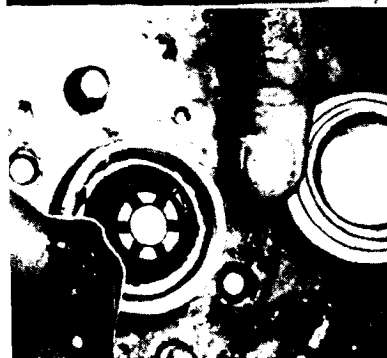

44

24

For the detailed indication of the prescribed maintenance jobs and the corresponding service periods see maintenance chart.

Specifications and maintenance instructions for Lucas electrical equipment

Brake switch

Model HL2 Part No. 31082
An hydraulically operated switch screwed into the brake line and actuated by the increase in fluid pressure which occurs when the brakes are applied. Contains a diaphragm and contacts which close to switch on the stop lights. The terminal connections should be checked occasionally and tightened if loose.

Cable and sundry clips, etc.

Part No. 795000 (R.H.D.)
795380 (L.H.D.)

The wiring and sundries include main, body and rear harnesses; panel, battery, and dynamo/starting motor cables; snap-connectors, grommets, clips, P.V.C. tubing, etc.

Dipper switch

Model 9RW Part No. 31704
A two-way switch for selecting dipped or main beam illumination from the double-dipping headlamps. The terminal connections should be checked occasionally and tightened if loose.

Direction indicator switch

Model SD84 Part No. 31695
A two-way-and-off switch for controlling the flasher lamps. The terminal connections should be checked occasionally and tightened if loose.

Flasher lamps

Model 559 Part No. 53362
Access to the bulb is gained by slacken-

ing the single lens securing screw and withdrawing the lens. The bulb is Lucas No. 382 12-volt 21 watt S.C.C. cap. It is important that only bulbs of this wattage are used (figure 45).

Flasher unit

Model FL5 Part No. 35012
The flasher unit is housed in a small cylindrical metal container which is sealed to prevent the ingress of foreign matter. Inside, a switch is operated automatically by the alternate heating and cooling of an actuating wire. Also incorporated is a small relay to flash the panel warning light when the system is functioning correctly.

Flasher warning light

Model WL13 Part No. 38102
The purpose of the instrument panel warning light is to assure the driver that his direction signals are being given. In the event of the warning light failing to flash a check should be made for a defective bulb in the external flasher lamp and in the warning light.

Access to the warning light bulb is gained by withdrawing the bulb-holder from the rear of the panel. The bulb is Lucas No. 987 12-volt 2.2 watt M.E.S. cap (figure 46).

Fuse

Part No. 188216
The fuse is housed in a cylindrical metal container or fuse carrier located beneath the instrument panel. It protects the circuits of the ignition auxiliaries, namely the flashers, horn, stop lights and windscreen wiper which are fed through the ignition switch (figure 47).

Access to the fuse is gained by releasing the bayonet-fixed end cap of the fuse carrier with a press-in anti-clockwise

25

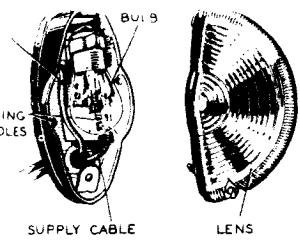

45

motion. The fuse is a 25-ampere glass cartridge type and care must be taken when inserting a replacement to see that the insulating sleeve is correctly fitted inside the carrier.

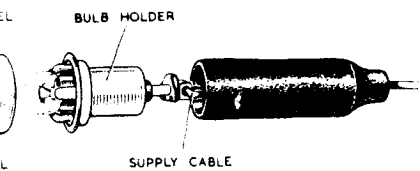

46

Before replacing a blown fuse, inspect the wiring of the affected circuits for evidence of a short circuit. It is important to use only the correct replacement fuse.

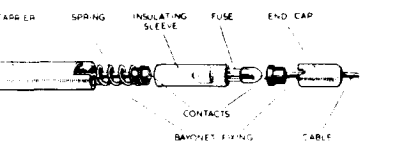

47

If the fuse blows repeatedly and the cause cannot be traced, the equipment should be examined at a Lucas Service Depot or by an official Lucas Agent.

Headlamp setting

The headlamps (figure 48) should be set so that when the vehicle carries its normal load the main beams are projected straight ahead, parallel with each other and with the road. The setting should always be checked after replacing a main bulb.

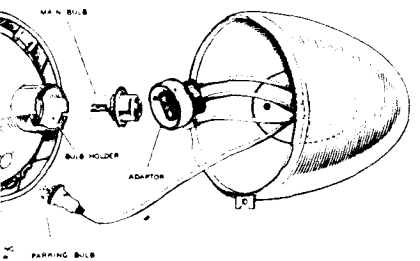

48

Owners are strongly advised to have their headlamps scientifically set with the aid of a Lucas Beam Setter. When such facilities are not available, however, the lamps can be set by marking off a smooth wall or screen and shining the lamps on it from a distance of at least twenty-five feet. Details are shown in (figure 49).

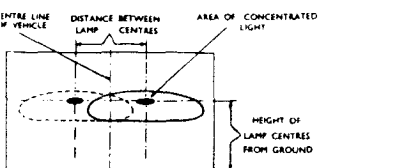

49

The lamps are secured to the car body by four set screws, access to which is gained by removing the interior trim panels. These screws must be slackened when it will be found that the lamp bodies can be adjusted to give the correct setting.

- (A) FRONT OF VEHICLE TO BE SQUARE WITH SCREEN
- (B) VEHICLE TO BE LOADED AND STANDING ON LEVEL GROUND
- (C) RECOMMENDED DISTANCE FOR SETTING IS AT LEAST 25FT
- (D) FOR EASE OF SETTING ONE HEADLAMP SHOULD BE COVERED

Main beam warning light

Model WL13 Part No. 38145

The main beam warning light is connected in parallel with the headlamp main filaments and lights up when these are in use. In some countries it is an

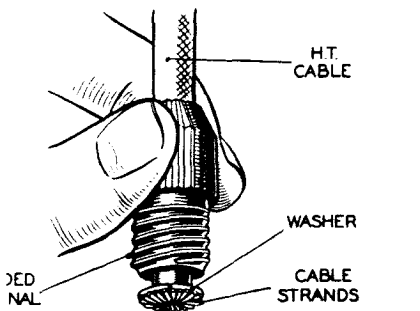

50

26

obligatory fitment intended to remind drivers to dip their headlamps when passing other vehicles.

Access to the warning light bulb is gained by withdrawing the bulb-holder from the rear of the instrument panel. The bulb is Lucas No. 987 12-volt 2.2 watt M.E.S. cap.

Horn Model HF1849 Part No. 70141 (Bracket 705179)

The horn is of the high frequency pattern deriving its note from the combined vibrations of a diaphragm and tone disc. These are coupled to an armature actuated electromagnetically as in an electric bell or buzzer.

Apart from an occasional inspection of the horn circuit cables and fixing bolts, the horn requires no maintenance. Worn or chafed cables must be renewed and the fixing bolts kept tight.

Horn push Model CC5 Part No. 33504

The horn push is located in the hub of the steering wheel and requires no attention in service.

Ignition coil Model LA12 Part No. 45053

The ignition coil should be kept clean, particular attention being paid to the terminal moulding. From time to time check the terminals for loose connections and tighten as necessary. Renew the high tension cable if it shows signs of perishing or cracking. To do this, remove the defective cable but do not lose the moulded terminal nut or split washer. Thread the new cable through the terminal nut and bare the end of the cable for about $\frac{1}{4}$ in. Thread the exposed strands through the split washer and bend them back radially. Refit the moulded nut into the terminal moulding (figure 50).

Ignition capacitor Part No. 425212

The ignition capacitor is clipped to the side of the ignition coil. It is of the metallised paper self-healing type and requires no attention in service beyond an occasional check of the ignition coil terminal "CB" to which it is connected.

Ignition warning light

Model WL13 Part No. 38100

The ignition warning light serves the dual purpose of reminding the driver to switch off the ignition before leaving the vehicle and of acting as a no-charge indicator. When the ignition is switched on, the warning light should be illuminated only when the engine is stopped or turning over very slowly. As the engine accelerates, the light should dim and go out at a fairly low engine speed. Failure of the light to behave in this way will indicate a fault in the charging system.

Access to the warning light bulb is gained by withdrawing the bulb-holder from the rear of the instrument panel. The bulb is Lucas No. 987 12-volt 2.2 watt M.E.S. cap.

Number plate lamp

Model 467/2 Part No. 53650

Access to the bulb is gained by slackening the single cover securing screw and withdrawing the cover. The bulb is Lucas No. 222 12-volt 4 watt M.C.C. cap (figure 51).

Reflex reflectors

Model RER5 Part No. 57075

The reflex reflectors are made of a thermoplastic material, resistant to attack by oil, petrol, paraffin, etc. They should be kept clean.

27

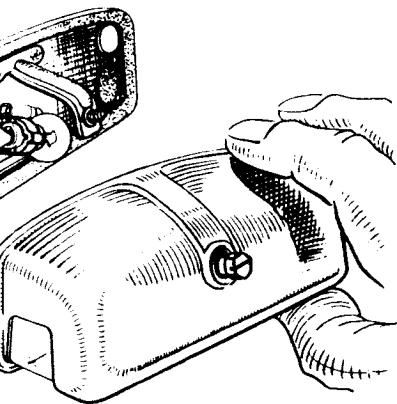

51

Stop-tail lamps

Model 488 Part No. 53178
Access to the bulb is gained by peeling back the outer rubber lip to release the rim and the inner lip to release the glass. The bulb contains two filaments of differing power and is, therefore, made non-reversible. The bulb is Lucas No. 380 12-volt 21/6 watt S.B.C. (Indexed) cap (figure 52).

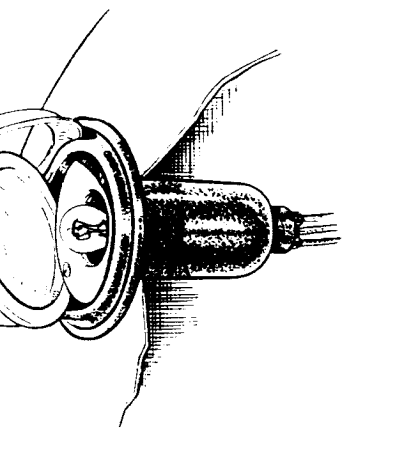

52

Windscreen wiper

Bosch Ltd.

The windscreen wiper motor has its bearing, bearing surfaces and gears well lubricated during manufacture and, normally, will require no further attention. The blades are brought into play by turning the switch lever located on the motor cover.

Efficient wiping is dependent on having a clean windscreen and wiper blades in good condition. Methylated spirits (denatured alcohol) should be used to remove oil, tar spots and other stains from the windscreen. Silicone and wax based polishes should not be used for this purpose. Worn or perished wiper blades are readily removed for replacement as shown in figure 53.

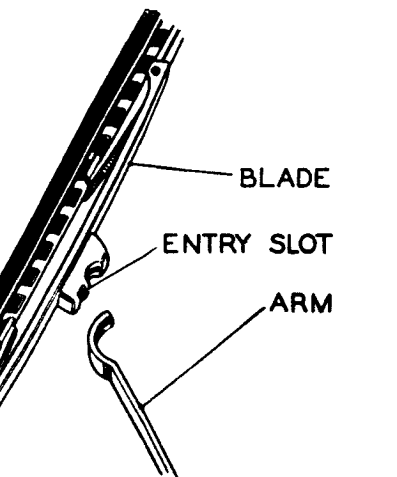

53

Wiring diagram

A copy of the wiring diagram is in the appendix of this handbook, but additional copies will be sent free on request to the Advertising Department, Joseph Lucas, Great King Street, Birmingham 19.

28

Minor inspections and adjustments

Many Isetta owners who have already possessed a motorcycle or a scooter will have the technical knowledge to do minor repairs themselves. This handbook, therefore, includes a number of repair jobs which may be undertaken by those drivers who in addition to their technical knowledge possess the requisite tools and appliances, gauges, car lifts, support stands, etc. These instructions are included so that the Isetta owner may have the jobs performed at places which lack an authorised Isetta Service Station.

Sparking plugs

Removal of the screw-plate on the body panel behind the seat-squab gives access to the cylinder head of the engine for the sparking plug and valve treatment (figure 54). Remove the sparking plug with the aid of a spark plug spanner (figure 55), clean it with a wire brush (figure 56) and reset the electrode gap (.024) by means of a gauge (figure 57).

Valves

Valve checking and adjustment as indicated along the following lines should be carried out every 2,000 miles. The valves are adjusted at T.D.C. compression when the valves are closed at the moment of ignition. The setting T.D.C. compression is described in detail on page 30, under ignition timing. Make it a rule not to adopt too small a clearance as this might cause the valves to burn and thus create major troubles. These adjustments to be carried out with the engine cold. Valve clearance should be .004—.006 in. for intake, .006—.008 in. for exhaust, with the engine cold. The adjustment of the valves requires two spanners. First slacken the locknut (figure 58), then turn the adjusting screw as required until the

29

54



55



56



57

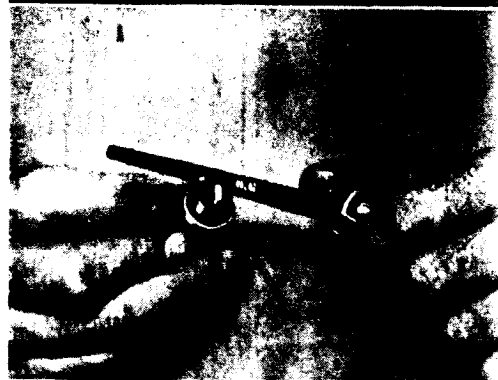



- 58 correct amount of play is felt with the feeler gauge inserted between rocker arm and valve stem end (figure 59). When this is obtained, hold adjuster with its spanner and retighten the locknut securely. When this nut is properly tightened, check the play again, to make certain that it has not been altered while tightening the nut.



When adjusting the valves you should inspect the rocker-box cover-gasket and replace it, if necessary, in order to ensure the proper sealing of the rocker-box (figure 60). Place the gasket in such a way that the two locating pins fit in the two holes of the gasket. Special care

- 59 should be taken in replacing the rocker covers to see that the locating pins engage exactly in the corresponding drilled holes provided in these units (figure 61). The figures illustrating the servicing of the valves in this booklet are shown with the engine in a completely accessible condition after removal of the body. Normally, these jobs are performed through the cover plate located behind the seat squab, as shown on figure 54.



Ignition

60 The resetting of ignition timing requires a 12-V test lamp, a contact gauge (.016 in.) and a screwdriver.

To perform the setting proceed as follows:—

1. Withdraw spark plug connector, unscrew sparking plug and remove cover from the blower wheel.
2. Rotate blower wheel in a clockwise direction until the colour-marked blade meets the mark "S" on the housing of the blower unit.

Now continue turning the blower wheel until the breaker contact points are fully opened.



61

30

3. Check contact breaker gap with the contact gauge .016 in. (figure 62) which must slip easily when being drawn fore and aft between the contact points. If the gap is too big or too small, slacken the stationary point locking screw 1 (figure 63), and turn the eccentric adjusting screw 2 (figure 63) until the correct gap is obtained. Then tighten lock screw 1 and recheck the gap.

4. Slacken the two contact plate securing screws (figures 64 and 65) and turn the blower wheel until the colour-marked blade meets the mark "S" on the blower housing.

Now disconnect black coloured contact breaker lead from terminal CB of ignition coil and connect the test lamp with one pole to terminal 1 of ignition coil and the other to the connector end of the disconnected black lead.

5. Push in ignition key to switch on ignition and move the contact breaker plate contrary to rotation direction (upwards) until the lamp lights up. Then move contact breaker plate carefully in direction of rotation (downwards) until the lamp just goes out. In this position tighten the contact breaker plate.

6. Withdraw ignition key to switch off ignition, detach test lamp, reconnect contact breaker lead to terminal 1 of ignition, detach test lamp, reconnect wheel, replace spark plug and push high-tension lead connector over the sparking plug.

Carburettor

The arrangement of jets and the carburettor adjustment have been tested at the factory in order to obtain the best performance and a maximum of economy

62

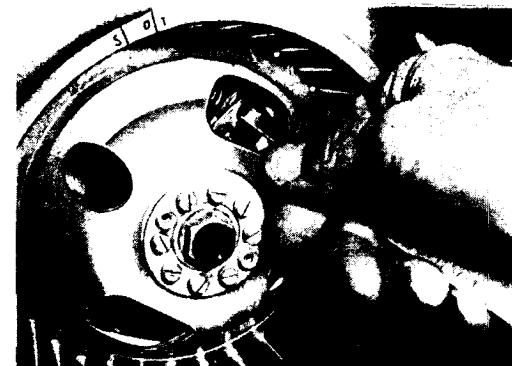

63

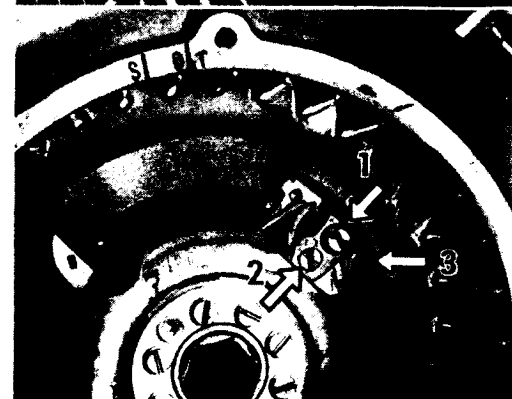

64

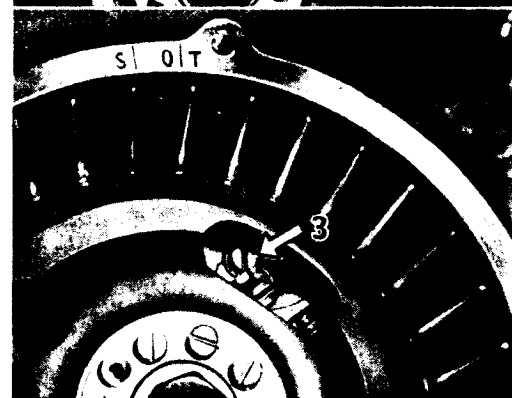

65





66 in consumption. It is, therefore, pointless to try and increase performance or to lower fuel consumption by altering the carburettor adjustment or by fitting jets of other sizes. It is possible to lower the fuel consumption by using smaller jets, but this will immediately cause an appreciable loss of power; there is the risk of the engine overheating and of the valves burning. In short, major repairs will become necessary. Consequently this chapter includes only those jobs which can be done for the maintenance and servicing of the carburettor.



67 The carburettor is regulated by means of two screws (figure 67) and the idling adjusting screw (figure 66). The volume control screw is best left with its original adjustment as set at the factory. If this adjustment has been altered by some cause, slacken lock nut of the volume control screw, turn the screw fully in with a screw driver, and then back it off by $1\frac{1}{2}$ —2 turns. This is best done with a special tool and, therefore, you should leave the job to an expert (figure 68).



The regulating and adjusting described above is all that can be done on the carburettor, by either layman or expert. To clean the carburettor, open the drain plug on the bottom of the float chamber (figure 69) having first set the fuel tap (figure 6) into its "OFF" position. Should it become necessary to remove the top of the carburettor ensure that the gasket sealing is replaced correctly.

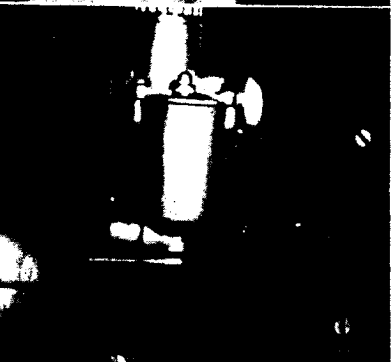

Chain

The power output of the engine is transmitted to the rear wheels by means of a chain running in an oil bath. Since it is completely protected this chain has a long life. It should, however, be adjusted

69

from time to time. The striking of the chain against its case will tell you when the chain has lengthened and needs adjustment. This is done by means of a perforated adjuster plate on the chain case (figure 70), which is accessible from the side opposite the engine. Remove the adjuster plate locating-screw with an appropriate spanner (figure 70). Then raise it with a screwdriver from the bottom upwards until strong resistance prevents further movement (figure 71). This re-establishes the proper tension of chain. The next problem is to get the drill holes in the adjuster plate corresponding with one of the two screw holes in the chain case. This cannot be done by forcibly lifting the plate until the holes meet one another (figure 72) because this would result in excessive chain tension. If the hole in the chain case happens to stay between two adjuster plate holes, slacken off in order to get the locating screw into its hole.

Clutch

The free movement of the clutch pedal should be about .48 in. to .6 in. The readjustment of clutch pedal clearance takes place on the clutch actuating lever at the transmission case and, like the chain adjustment, is achieved from the side opposite the engine. This can be done with the vehicle supported at the rear, entering the spanner from behind. Turning the adjuster screw clockwise increases clutch pedal clearance and contrary adjustment decreases it (figure 73).

Brakes

The foot brake is hydraulic. It affects all four wheels, since the two rear wheels

70



71

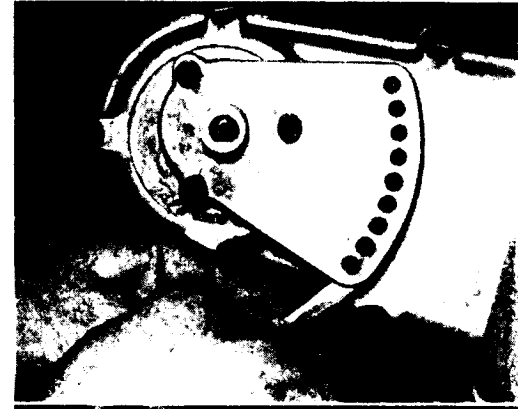

72

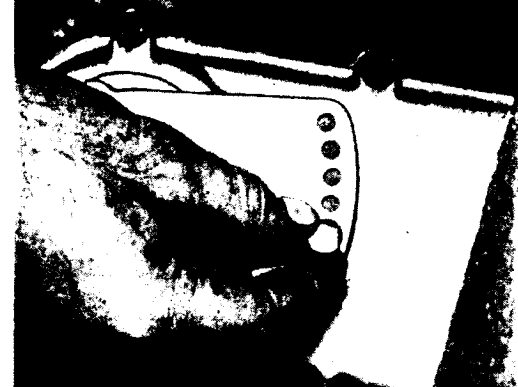

73

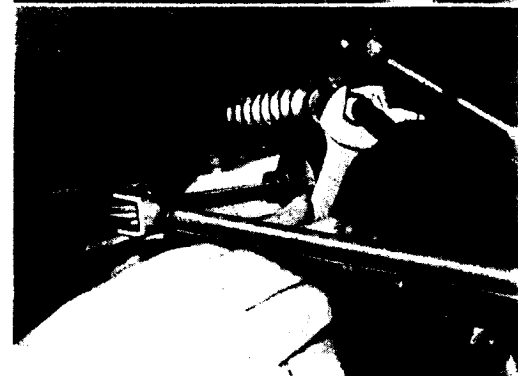

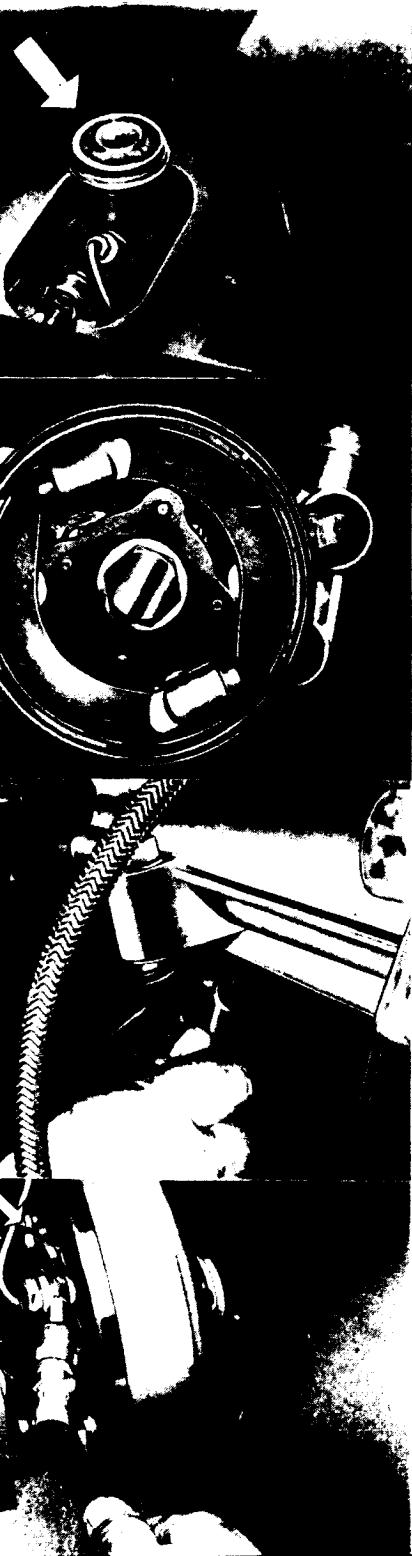

74 are mounted on a rigid scale. Maintenance of the brake includes checking the brake fluid level. The brake-master cylinder with the fluid reservoir is situated below the seat bench and is accessible simply by unscrewing the filler plug. When removing it take care to avoid getting dirt into the brake fluid. Use only Girling crimson fluid from the original can (figure 74). If the brake pedal travels too freely, it is an indication that air has entered the hydraulic system; the fluid line must then be bled. This can best be done by a service station as it requires special devices and knowledge.

75 **Running adjustments**

Girling brakes are adjusted for lining wear only at the brakes themselves and on no account should any alteration be made to the handbrake cable for this purpose.

Front brakes (figures 75 and 76)

A separate snail cam adjuster is provided for each shoe. Jack up the vehicle until the front wheel to be adjusted is clear of the ground, then fully release both adjuster bolts on outside of the back-plate by turning anti-clockwise.

76 Turn one of the adjuster bolts clockwise until the brake shoe concerned touches the brake drum then release the adjuster until the shoe is just free of the drum. Repeat the process for the second adjuster and shoe.

Spin the wheel to ensure that the brake shoes are quite free of the drum. Repeat the whole procedure for the second front wheel.

Rear brake (figure 77)

One common adjuster is provided for both shoes.

Release the handbrake and jack up the

car. Turn the square end of the adjuster on the outside of the rear brake back-plate in a clockwise direction until a resistance is felt, slacken two clicks, when the drum should rotate freely.

Immediately after fitting replacement shoes it is advisable to slacken one further click to allow for possible lining expansion, reverting to normal adjustment afterwards.

Maintenance survey

All jobs mentioned in the preceding chapters for the proper maintenance and servicing of your vehicle are arranged in the following service groups and in the maintenance chart. The most frequent jobs form Service A, to be performed every 1,000 miles. The more complicated jobs to be done at longer intervals form Service B and Service C.

The experienced mechanic will on a "C" Service check the entire chassis, brake and steering assemblies as well as all stationary and movable parts, and eventually provide them with the necessary paint and anti-corrosion coatings.

In addition to Services A, B and C the following jobs should be done:

(a) After the first 300 miles:—

1. Drain engine oil, remove oil sump, clean it and wash the oil screen, refit sump and refill with fresh oil.
2. Remove valve rocker covers and tighten the four cylinder head holding down bolts to a torque loading of 32 lbs. ft. This operation should, of course, be carried out diagonally. Re-adjust tappets with engine cold (see "Valves", page 29) and refit rocker covers.
3. Check and re-tighten if necessary cylinder base nuts, Part No.

00 01 509, using a 12 mm. flat ring spanner.

(Note: Free Service, but oil is chargeable.)

(b) At 600 miles:—

1. Change oil in gearbox, rear drive and engine. Oil and grease chassis points, oil all hinges and joint.
2. Check front suspension mountings.
3. Check and tighten all nuts and bolts, including transmission, universal coupling bolts and wheel nuts.
4. Check electrolyte level of battery, add distilled water, give posts and terminals a grease coating.
5. Remove valve rocker covers and tighten the four cylinder head holding down bolts to a torque loading of 32 lbs. ft. This operation should, of course, be carried out diagonally. Re-adjust tappets with engine cold (see "Valves," page 29) and refit rocker covers.
6. Check and re-tighten if necessary cylinder base nuts, Part No. 00 01 509, using a 12 mm. flat ring spanner.
7. Clean sparking plug and adjust gap.
8. Check ignition points, readjust if necessary.
9. Remove carburettor, clean out jets and petrol filter, clean throttle slide and ensure needle is in correct slot, ensure correct clearance on throttle and choke cables.
10. Adjust slow running, clean out air intake filter.

11. Check brake fluid, top up if necessary, check brakes and adjust if required.

12. Check tyre pressures (see page 9).

(Note: Free Service, but oil is chargeable.)

Service A (after first 1,600 miles and thereafter at every 1,000 miles)

1. Oil change in engine.
2. Greasing :
 - (a) Top bearings of steering knuckle, left and right.
 - (b) Bottom bearings of steering knuckle, left and right.
 - (c) Handbrake cable.
 - (d) Steering arm shaft.
 - (e) Universal joint of steering (in cabin).
 - (f) Pedal shaft (in cabin).
3. Check tyre pressures on all wheels.

Service B (after first 2,600 miles and thereafter at every 2,000 miles)

1. Maintenance Service A.
2. Check oil level in transmission, top up if necessary.
3. Check oil level in reservoir lubricating fulcrum bearings of swing arm and torque arm, left and right.
4. Check oil level in chain drive, top up if necessary.
5. Check electrolyte level of battery, add distilled water, give posts and terminals a grease coating.
6. Check ignition, readjust if necessary.

7. Clean sparking plug, adjust electrode gap.

8. Check valves and readjust if necessary.

9. Check brake fluid, top up if necessary.

10. Check brakes, reset if necessary.

11. Oil all hinges, joints and control cables.

12. Check gear-change control mechanism.

13. Clean carburettor, tune if necessary.

14. Remove fuel filter screen on fuel inlet and clean it.

15. Clean air filter.

16. Change tyres.

17. Oil speedometer gear box (4-wheel model only)

Service C (every 7,500 miles)

1. Maintenance Service A.
2. Maintenance Service B.
3. Remove battery and recharge.
4. Change oil in transmission.
5. Change oil in chain drive.
6. Remove brake drums and check brake linings.
7. Clean all Bowden cables, readjust, replace if necessary.
8. Replace cleaning element of air filter.

The Isetta Company, whose policy is one of continuous improvement, reserves the right to change specifications and equipment without incurring obligation. Reasonable tolerances should be applied to dimension, weight and performance figures given.

Lubrication and maintenance chart Jobs to be performed

The numerals indicate the lubrication points and correspond with the illustration on the margin.

1. Pedal shaft—lubricating grease.
2. Universal joint, steering—lubricating grease.
3. Steering arm shaft — lubricating grease.
4. Upper bearing steering knuckle king pin, left and right — lubricating grease.
5. Lower bearings steering knuckle king pin, left and right—lubricating grease.
6. Handbrake cable.
7. Wheel bearings, left and right — lubricating grease.
8. Oil reservoir for fulcrum bearings of swing arm and torque arm, left and right—use Branded Oil SAE 40.
9. Brake master cylinder—Girling brake fluid crimson.
10. Battery—distilled water.
11. Contact breaker—lubricating grease.
12. Engine—engine oil.
13. Rear suspension leaf spring—Esso Penetrating Oil.
14. Rear drive—engine oil.
15. Air-cleaner.
16. Transmission—engine oil.

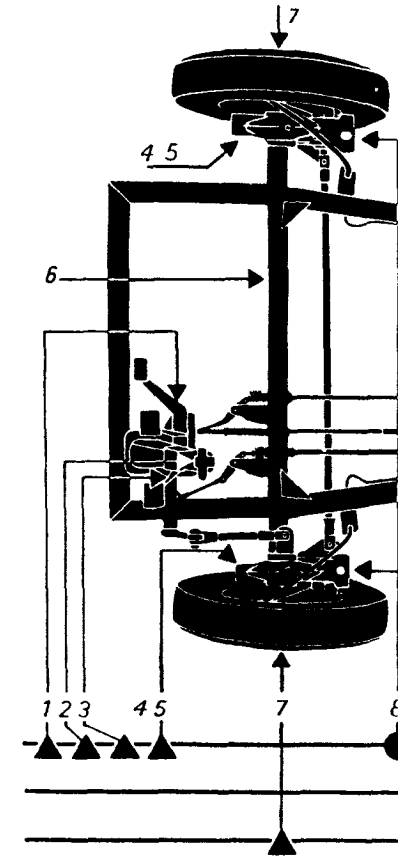
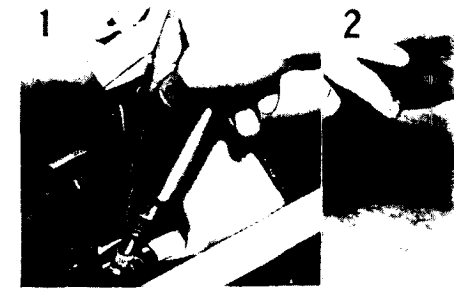

Lubrication and maintenance chart Jobs to be performed

The numerals indicate the lubrication points and correspond with the illustration on the margin.

1. Pedal shaft—lubricating grease.
2. Universal joint, steering—lubricating grease.
3. Steering arm shaft — lubricating grease.
4. Upper bearing steering knuckle king pin, left and right — lubricating grease.
5. Lower bearings steering knuckle king pin, left and right—lubricating grease.
6. Handbrake cable.
7. Wheel bearings, left and right — lubricating grease.
8. Oil reservoir for fulcrum bearings of swing arm and torque arm, left and right—use Branded Oil SAE 40.
9. Brake master cylinder—Girling brake fluid crimson.
10. Battery—distilled water.
11. Contact breaker—lubricating grease
12. Engine—engine oil.
13. Rear suspension leaf spring—Esso Penetrating Oil.
14. Rear drive—engine oil.
15. Air-cleaner.
16. Transmission—engine oil.

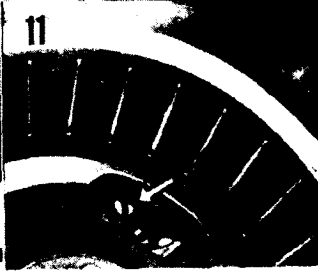
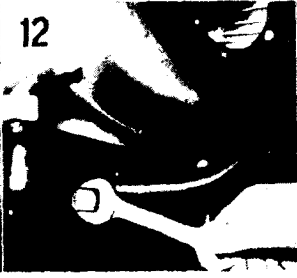
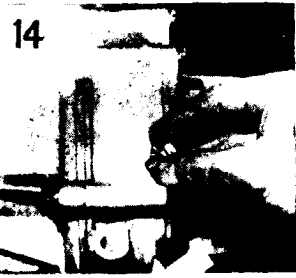
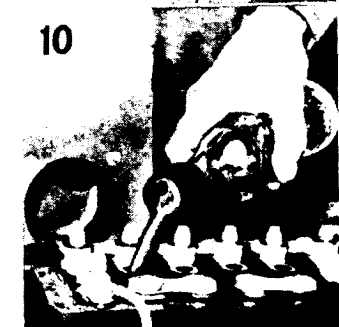
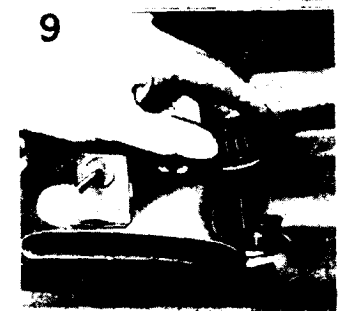
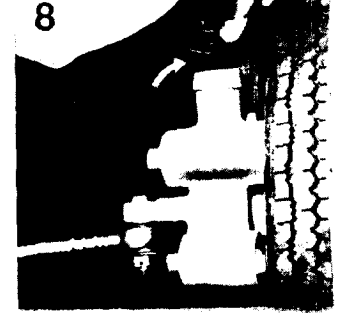
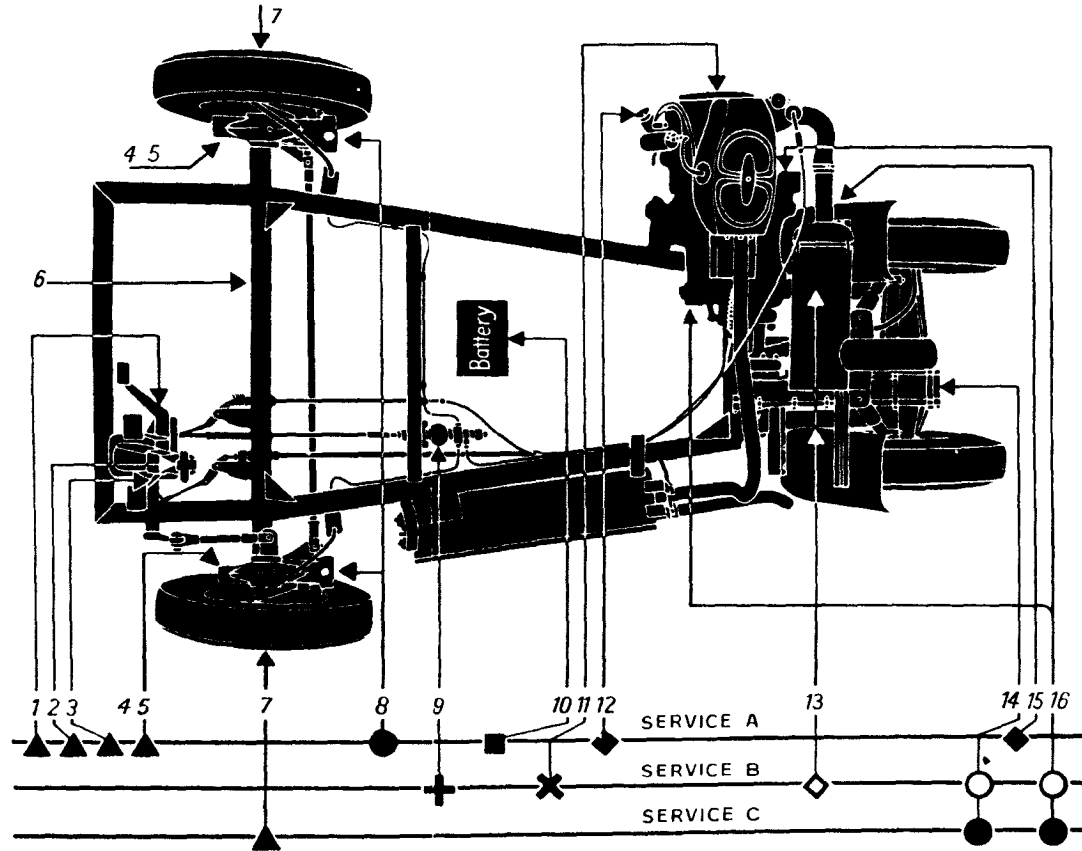
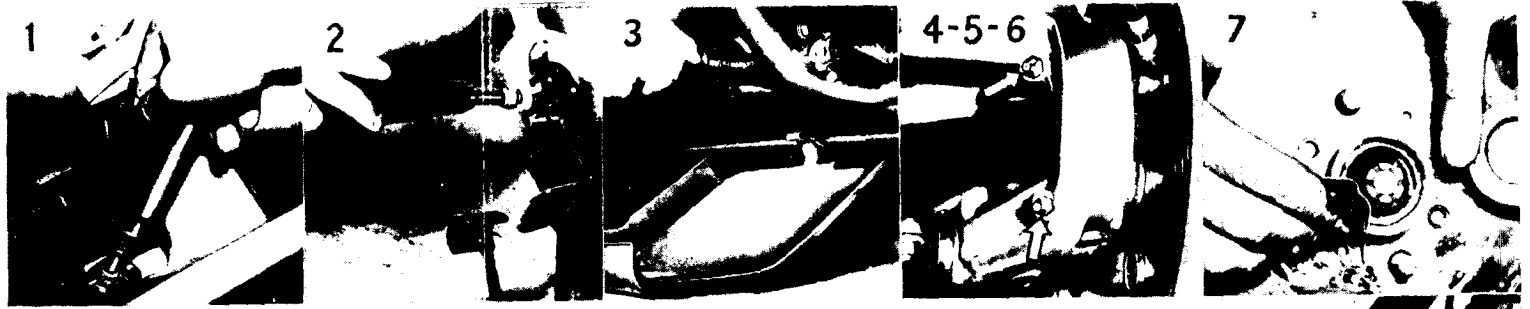

L.H. HEADLAMP

KEY TO WIRING DIAGRAM

- | | |
|-----------|----------------------|
| B. Black | LG. Light Green |
| N. Brown | BR. Brown and Red |
| Y. Yellow | WR. White and Red |
| U. Blue | GB. Green and Black |
| G. Green | GR. Green and Red |
| R. Red | UW. Blue and White |
| W. White | GP. Green and Purple |
| | UR. Blue and Red |

NOTE: The battery positive to 51/30 shown on the wiring diagram as brown, is in fact, red.

RECOMMENDED LUBRICANTS

	MARK	SHELL	BP
ENGINE U.K.: Summer .. Winter Overseas: above 32°F. .. 10°F. to 32°F. .. Below 10°F.	◆	SHELL X-100 MULTIGRADE 20W/40 or SHELL X-100 40	ENERGOL VISCO-STATIC or ENERGOL SAE 40
		SHELL X-100 MULTIGRADE 20W/40 SHELL X-100 20/20W	ENERGOL VISCO-STATIC or ENERGOL SAE 20W
		SHELL X-100 MULTIGRADE 20W/40 or SHELL X-100 40	ENERGOL VISCO-STATIC or ENERGOL SAE 40
		SHELL X-100 MULTIGRADE 20W/40 or SHELL X-100 20/20W	ENERGOL VISCO-STATIC or ENERGOL SAE 20W
		SHELL X-100 MULTIGRADE 10W/30	ENERGOL VISCO-STATIC
TRANSMISSION, FINAL DRIVE & FRONT SUSPENSION	●	SHELL X-100 MULTIGRADE 20W/40 or SHELL X-100 40	ENERGOL VISCO-STATIC or ENERGOL SAE 40
GREASE LUBRICATED PARTS	▲ OR X	SHELL RETINAX A.	ENERGREASE I. 2
REAR SPRING	□	SHELL DONAX P.	ENERGOL PENETRATING OIL
BATTERY BRAKE FLUID	■ +	DISTILLED WATER WAKEFIELD GIRLING BRAKE AND CLUTCH FLUID CRIMSON	

NOTE: When undertaking frequent short journeys it is recommended that the oil should be changed every 750 miles.

See Inset for Lubrication and Maintenance Chart/Wiring Diagram

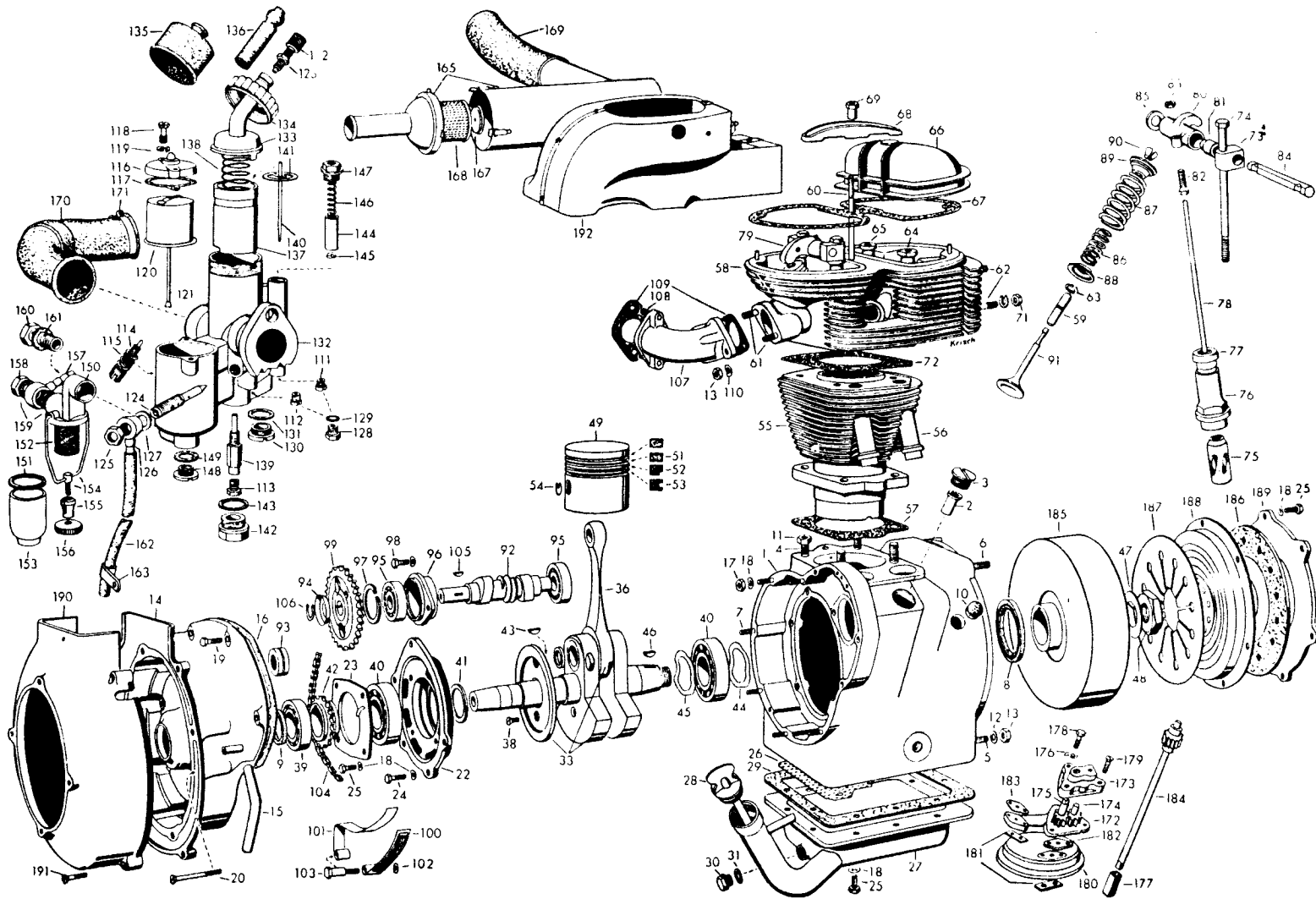

250
300

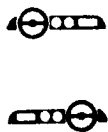

**Motor
Engine**

- Steuerungsantrieb und Motorentlüftung, Vergaser
- Timing drive and engine ventilation, carburetor

11.3

8/17

1.10.1967

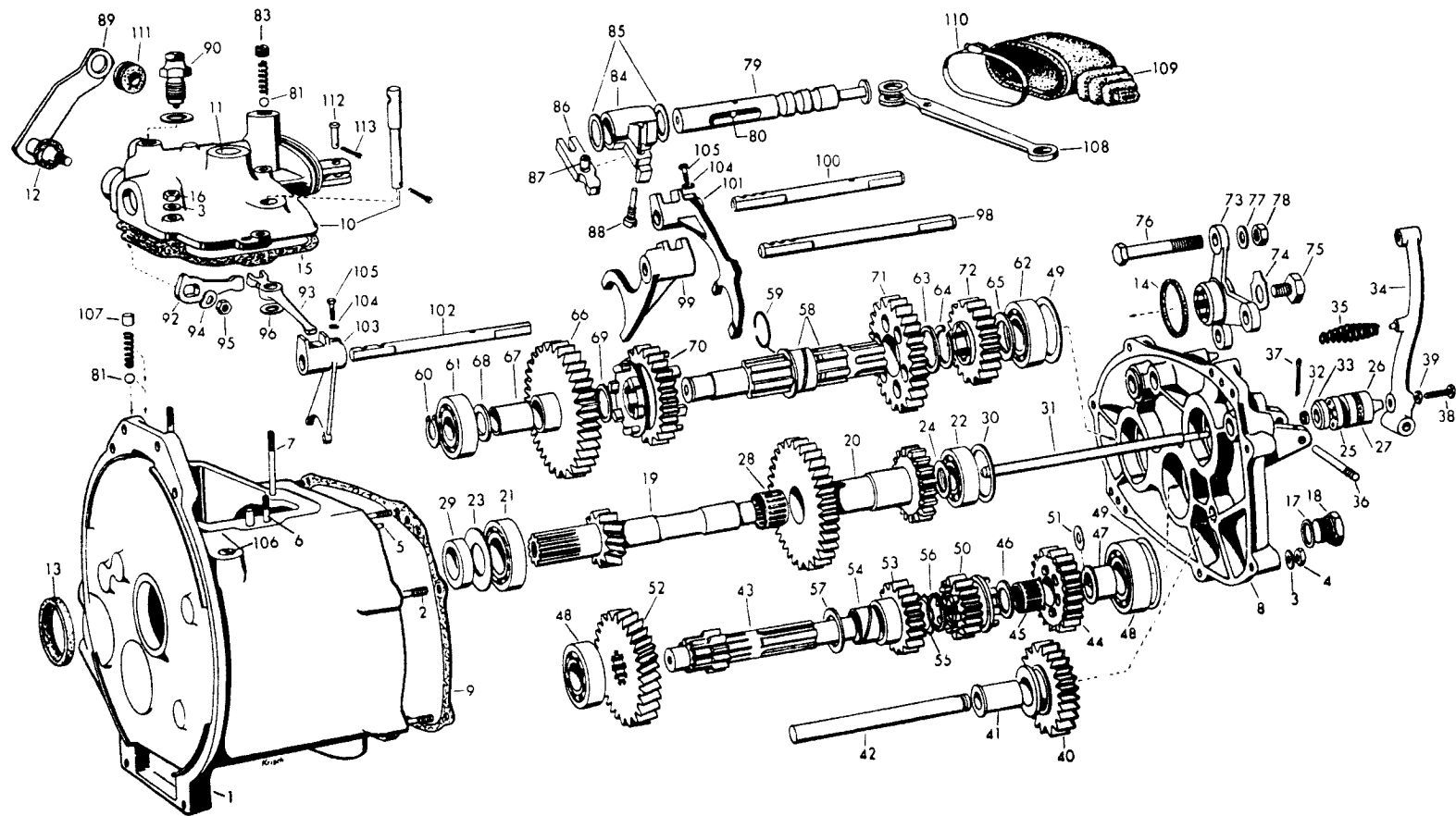

RECHTSLENKUNG

Rechtslenkung sind nur die Teile aufgeführt die
für den Export-Ausführung unterschieden

RIGHT-HAND DRIVE

Right hand drive deals with the parts which differ
of the Export Model



**Getriebe (Rechtslenkung)
Gear box (Right-hand drive)**

- Getriebegehäuse
- Gear box housing

23.1

7/8

1.10.1967

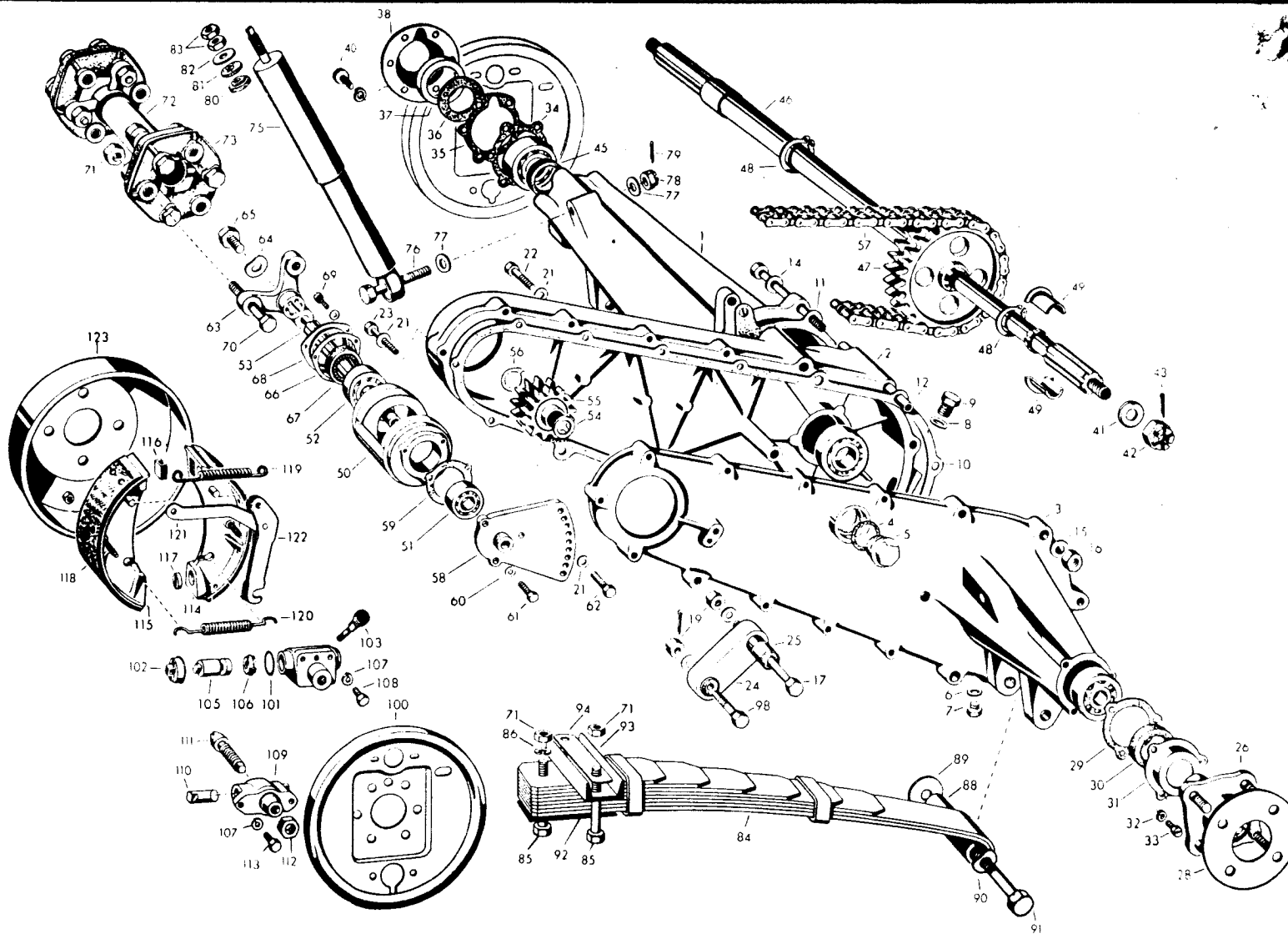

D
 Dreirad sind nur die Teile aufgeführt die sich
 „Export-Ausführung“ unterscheiden.

WHEEL
 Wheel deals with the parts which differ from
 Export Model



- Hinterachse (Dreirad)** – Stoßdämpfer, Hinterachsfederung, Längslenker zur Hinterachse, Bremsleitungen, Handbremsseil, Auspuffanlage
- Rear axle (Three-Wheel)** – Shock absorber, rear axle springing, axial control arm to rear axle, brake lines, hand brake cable, exhaust system

33.3+34.3

10/10

1.10.1967